

## MATRIX<sup>EVO</sup> Tritone LED Panel

Thanks for choosing our MATRIX EVO Power Switchable Tritone LED Panel  
We strongly recommend that you read this manual carefully before installation.

| model            | size     | Watts               | CCT    | Luminous flux ±10% | Beam angle | IP Rating | Input voltage       | LED type | CRI | PF   |
|------------------|----------|---------------------|--------|--------------------|------------|-----------|---------------------|----------|-----|------|
| MATX0606-EV      | 595*595  | 28W/32W/<br>36W/40W | 3000K  | 2750-4400LM        | 110°       | IP40      | 220-<br>240VAC/60HZ | 2835     | ≥80 | >0.9 |
|                  |          |                     | 4000K  |                    |            |           |                     |          |     |      |
|                  |          |                     | 5000K  |                    |            |           |                     |          |     |      |
| MATX0606-25W-EV  | 28W      | 3000K               | 2750LM |                    |            |           |                     |          |     |      |
|                  |          | 4000K               |        |                    |            |           |                     |          |     |      |
|                  |          | 5000K               |        |                    |            |           |                     |          |     |      |
| MATX0312-EV      | 295*1195 | 28W/32W/<br>36W/40W | 3000K  | 2750-4400LM        |            |           |                     |          |     |      |
|                  |          |                     | 4000K  |                    |            |           |                     |          |     |      |
|                  |          |                     | 5000K  |                    |            |           |                     |          |     |      |
| MATX03012-25W-EV | 28W      | 3000K               | 2750LM |                    |            |           |                     |          |     |      |
|                  |          | 4000K               |        |                    |            |           |                     |          |     |      |
|                  |          | 5000K               |        |                    |            |           |                     |          |     |      |

### WARNING

The luminaire must be installed by professional electrician.  
Switch power off when wiring the luminaire.  
Ensure input voltage conforms to the voltage range of product.  
Ensure wires are securely connected.  
Before switching on, ensure that all the wiring is correct.  
The warranty is void if product is not installed according to the instructions.

### Installation Instructions

- Power off before installation.
- Ensure that the installed object can bear the lamp weight. Open the groove on the ceiling according to corresponding size. Then install the lamp into the clamping groove on the ceiling.
- Then connect wire attached to the lamp onto the corresponding power cord and carry out insulation sealing at the joint.

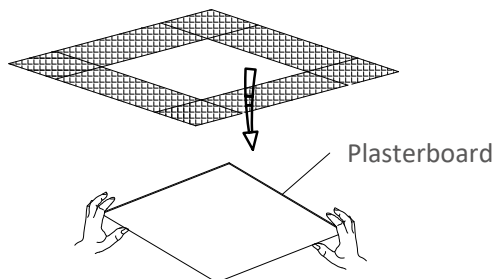

1. Remove the appropriate size plasterboard and plug the light into the ceiling.

Product Code:  
**MATX0312-EV**  
**MATX0312-25-EV**  
**MATX0606-EV**  
**MATX0606-25-EV**

## MATRIX<sup>EVO</sup> Tritone LED Panel

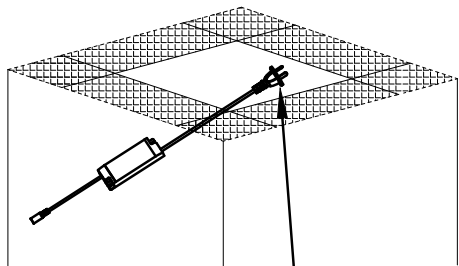

2. Insert the Australian standard plug into the butt plug. Note: Please make sure the wire is insulated.

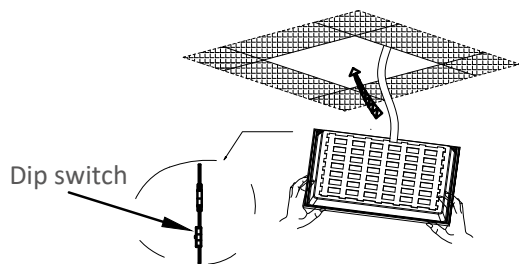

3. Adjust the color temperature to the desired color temperature through the dip switch, and then insert the DC male connector into the DC female connector.

### Dimensions (mm)

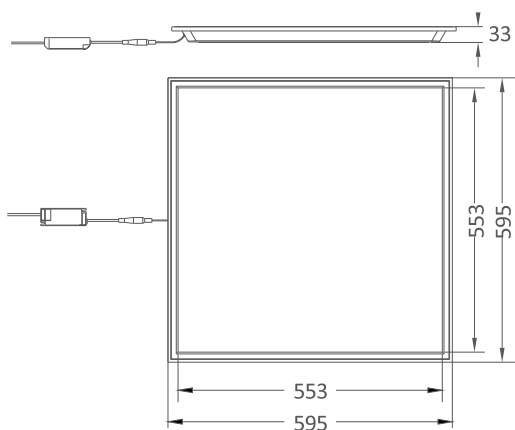

MATX0606-EV  
MATX0606-25-EV

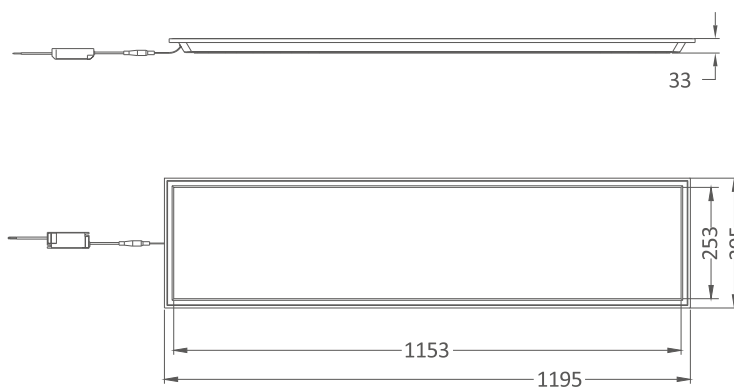

MATX0312-EV  
MATX0312-25-EV